

Mont  
Blanc®

# FURKA ROOF RACKS

NO TOOLS • NO WORRIES • NO ASSEMBLY NEEDED  
**EASY  
GO™**

WARRANTY • WARRANTY • WARRANTY  
**5  
YEAR**



ART N° 701000 (BLACK EDITION)  
701001 (SILVER EDITION)

GB FITTING INSTRUCTIONS  
SE MONTERINGSANVISNING  
FR INSTRUCTIONS DE MONTAGE  
ES INSTRUCCIONES DE MONTAJE  
DE MONTAGEANLEITUNG

IT ISTRUZIONI PER COMPONENT  
NL MONTAGEVOORSCHRIFT  
PT INSTRUÇÕES DE MONTAGEM  
RO INSTRUȚIUNI DE INSTALARE  
PL INSTRUKCJA MONTAZU

DN INSTALLATIONSVEJLEDNING  
FI ASENNUSOHJET  
NO INSTALLASJONSINSTRUKSJONER

**GB** WARNING:  
Read these instructions carefully before using the product for the first time.  
- Assemble and fit the product using these instructions only.  
- Keep instructions in car.  
- Be sure to follow the national rules and legislations in force regarding method of application of load carrier and accessories.  
- Do not assemble or use this product unless you have understood the fitting instruction. If you have any questions, please contact your local dealer for further information.

**SE** VARNING:  
Läs igenom anvisningen noggrant innan produkten tas i bruk.  
- Montera endast enligt denna beskrivning.  
- Monteringsanvisningen skall medföras i bilen.  
- Gällande nationella lagkrav och föreskrifter skall följas vad avser användningssätt för lasthållare och tillbehör.  
- Montera och använd inte produkten förrän du har förstått monteringsanvisningen. Vid eventuella oklarheter, kontakta återförsäljaren.

**FR** IMPORTANT:  
À lire soigneusement avant la première utilisation  
- Pour le montage, se conformer strictement aux présentes instructions.  
- Les instructions doivent nécessairement se trouver dans le véhicule.  
- Les arrêtés et lois nationaux en vigueur doivent être suivis lors de l'emploi du porte-bagages et de ses accessoires.  
- Ne pas assembler et ne pas utiliser le produit avant de lire les instructions de montage. Prendre contact avec le fournisseur lors de problèmes éventuels.

**ES** IMPORTANTE:  
Leer antes del primer uso.  
- Realizar el montaje únicamente conforme a estas instrucciones.  
- Llevar las instrucciones en el vehículo.  
- Reglas nacionales exigidas e instrucciones vigentes tienen que ser cumplidas al respecto del modo de uso de carga equipajes y accesorios.  
- No monte o utilice este producto hasta que haya comprendido las instrucciones de montaje. Si tiene alguna pregunta, por favor pongase en contacto con su distribuidor para más información.

**DE** WICHTIG:  
Vor Erstgebrauch lesen.  
- Montage nur nach dieser Vorlage durchführen.  
- Vorlage im Fahrzeug mitführen.  
- Geltende Rechte und Vorschriften müssen verfolgt werden bezüglich Verwendungsweise für Lastenträger und Zubehör.  
- Vor der Montage und Anwendung des Produkts, diese Montageanleitung sehr genau durchlesen. Bei eventuellen Unklarheiten bitte setzen Sie sich mit Ihrem Händler in Verbindung.

**IT** INFORMAZIONI:  
Leggere accuratamente le istruzioni prima di usare il prodotto per la prima volta  
- Adattare la ruota seguendo solo queste istruzioni.  
- Tenere le istruzioni in auto.  
- Assicurarsi di seguire le norme nazionali e le leggi in vigore riguardanti il metodo di applicazione del portapacchi e accessori.  
- Non assemblare o usare questo prodotto salvo aver capito le istruzioni per l'uso. Per qualsiasi domanda, contattare il rivenditore locale per ulteriori.

**NL** BELANGRIJK:  
Voor gebruik goed doorlezen.  
- Montage alleen volgens dit voorbeeld uitvoeren.  
- Montagevoorschrift in de auto bewaren.  
- Wettelijke regels en voorschriften ten aanzien van gebruik van allesdragers en accessoires moeten in acht worden genomen.  
- Dit product niet monteren en gebruiken voordat het montagevoorschrift geheel duidelijk is. Wend U met eventuele vragen tot de plaatselijke dealer.

**PT** ATENÇÃO:  
Ler antes de utilizar  
- Realizar a montagem conforme estas indicações.  
- Recomendamos manter estas instruções no seu automóvel.  
- Cumprir as regras nacionais e respectiva legislação a respeito do modo de utilização de carga e acessórios.  
- Não montar ou utilizar este produto sem ter compreendido e entendido as instruções de montagem. Se tive alguma questão queira por favor entrar em contacto com o distribuidor nacional.

**RO** AVERTISMENT:  
Citiți cu atenție aceste instrucțiuni înainte de a utiliza produsul pentru prima dată.  
- Asamblați și montați produsul folosind numai aceste instrucțiuni.  
- Păstrați instrucțiunile în mașină.  
- Asigurați-vă că respectați normele și legislațiile naționale în vigoare privind metoda de aplicare a suportului de sarcină și a accesoriilor.  
- Nu asamblați și nu utilizați acest produs decât dacă ați înțeles instrucțiunile de montare. Dacă aveți orice întrebări, vă rugăm să contactați dealerul local pentru informații suplimentare.

**PL** WAŻNE:  
Przed pierwszym użyciem przeczytać.  
- Montaż przeprowadzić zgodnie z niniejszą instrukcją.  
- Instrukcję należy umieścić w samochodzie.  
- Należy stosować się do obowiązujących przepisów dotyczących sposobu korzystania z bagażników i wyposażenia.  
- Przed zamontowaniem i użyciem niniejszego produktu należy bardzo dokładnie przeczytać niniejszą instrukcję montażu. W przypadku niejasności należy porozumieć się ze sprzedawcą.

**DN** ADVARSEL:  
Læs denne vejledning omhyggeligt, før du bruger produktet første gang.  
- Saml og monter kun produktet ved hjælp af denne vejledning.  
- Opbevar vejledningen i bilen.  
- Sørg for at følge de gældende nationale regler og love vedrørende anvendelsesmetode for lastbærer og tilbehør.  
- Monter eller brug ikke dette produkt, medmindre du har forstået monteringsvejledningen. Hvis du har spørgsmål spørgsmål, bedes du kontakte din lokale forhandler for yderligere information.

**FI** TÄRKEÄ:  
Luettava ennen ensimmäistä käyttöönottoa.  
- Asennus vain tämän ohjeen mukaan.  
- Pidettävä mukana ajoneuvossa.  
- Taakkatelineiden ja niiden lisätarvikkeiden käyttöä koskevia kansallisia lakeja ja muita säännöksiä on aina noudatettava.  
- Älä asenna äläkä käytä tuotetta ennen kuin olet ymmärtänyt asennusohjeet. Ota yhteyttä jälleenmyyjään epäselvissä tapauksissa.

**NO** ADVARSEL:  
Les disse instruksjonene nøye før du bruker produktet for første gang.  
- Monter og monter produktet kun ved hjelp av disse instruksjonene.  
- Oppbevar instruksjonene i bilen.  
- Sørg for å følge gjeldende nasjonale regler og lover når det gjelder bruk av lastbærer og tilbehør.  
- Ikke monter eller bruk dette produktet uten at du har forstått monteringsanvisningen. Hvis du har noen spørsmål spørsmål, vennligst kontakt din lokale forhandler for ytterligere informasjon.



**7,2 KG**

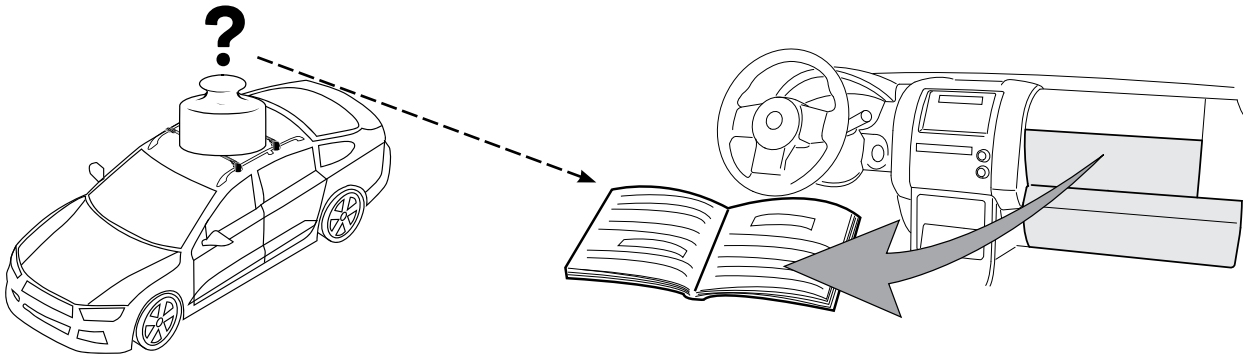
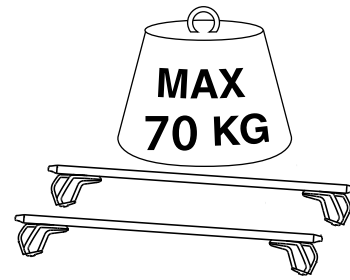

# FURKA ROOF RACKS

1

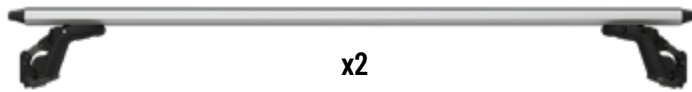

2

**FURKA ROOF BAR CLAMP KIT**



3

**FURKA ROOF BAR CLAMP KIT**

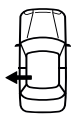

+

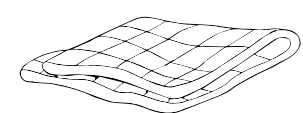

# FURKA : YOUR SPECIFICATIONS

**i** SCAN



[www.montblancgroup.com/furka](http://www.montblancgroup.com/furka)

SE DINA SPECIFIKATIONER  
FR VOS RÉGLAGES  
ES SUS ESPECIFICACIONES  
DE IHRE EINSTELLUNGEN  
IT LE VOSTRE SPECIFICHE

NL UW SPECIFICATIES  
PT AS SUAS ESPECIFICAÇÕES  
RO SPECIFICAȚIILE DVS.  
PL TWOJE SPECYFIKACJE  
DN DINE SPECIFIKATIONER

FI SINUN ERITELMÄNNE  
NO DINE SPESIFIKASJONER

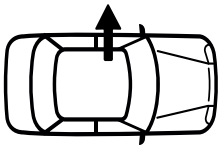

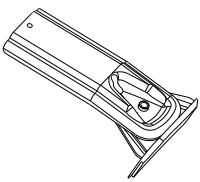
 **KIT :** .....

 .....

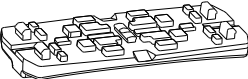
 .....

**X mm** .....

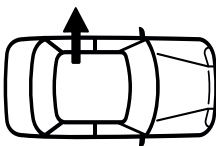

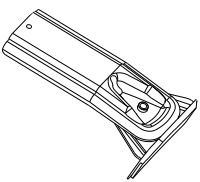
 **KIT :** .....

 .....

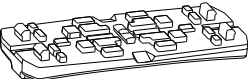
 .....

**Y mm** .....

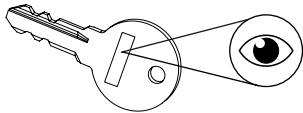
  **N°** .....

 **VIDEO MOUNTING TUTORIAL**



- SE MONTERINGSHANDLEDNING
- FR TUTORIEL DE MONTAGE
- ES TUTORIAL DE MONTAJE
- DE ANLEITUNG ZUR MONTAGE
- IT ESERCITAZIONE DI MONTAGGIO
- NL MONTAGEHANDLEIDING
- PT TUTORIAL DE MONTAGEM
- RO TUTORIAL DE MONTARE
- PL SAMOUCZEK MONTAŻU
- DN VEJLEDNING I MONTERING
- FI ASENNUSOHJEET
- NO MONTERINGSVEILEDNING

1

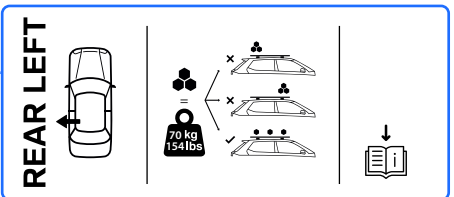
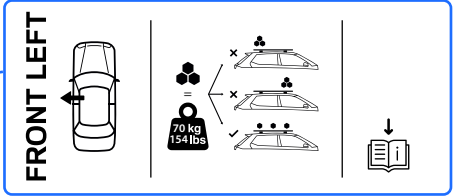
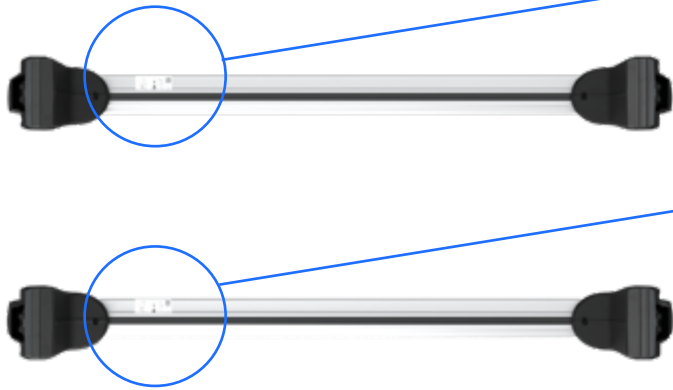

2



x4



x4

3

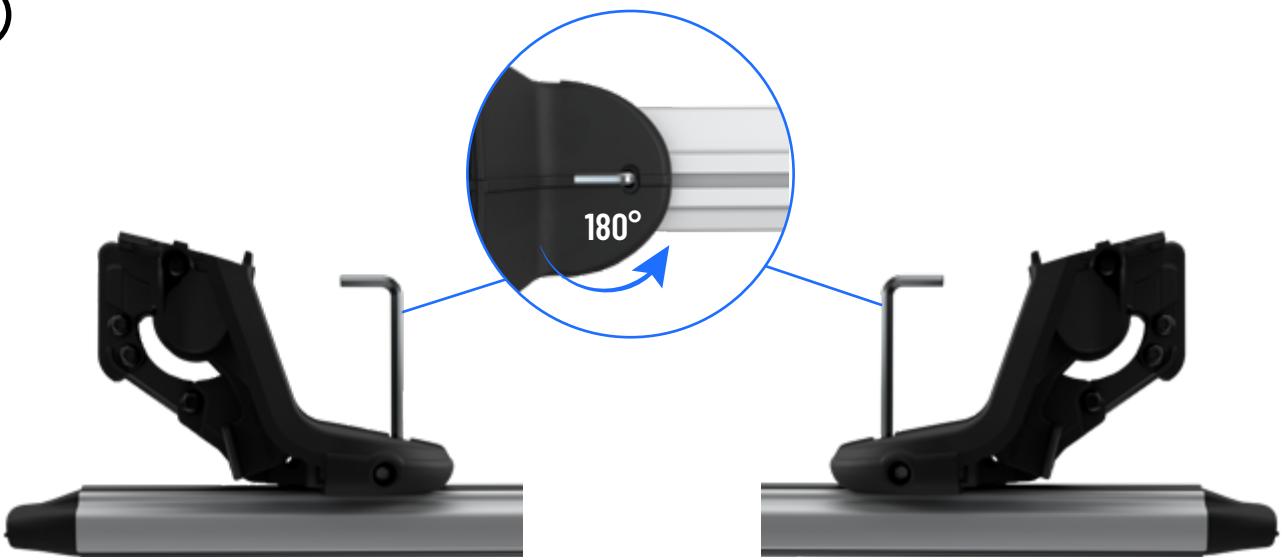

x4

4

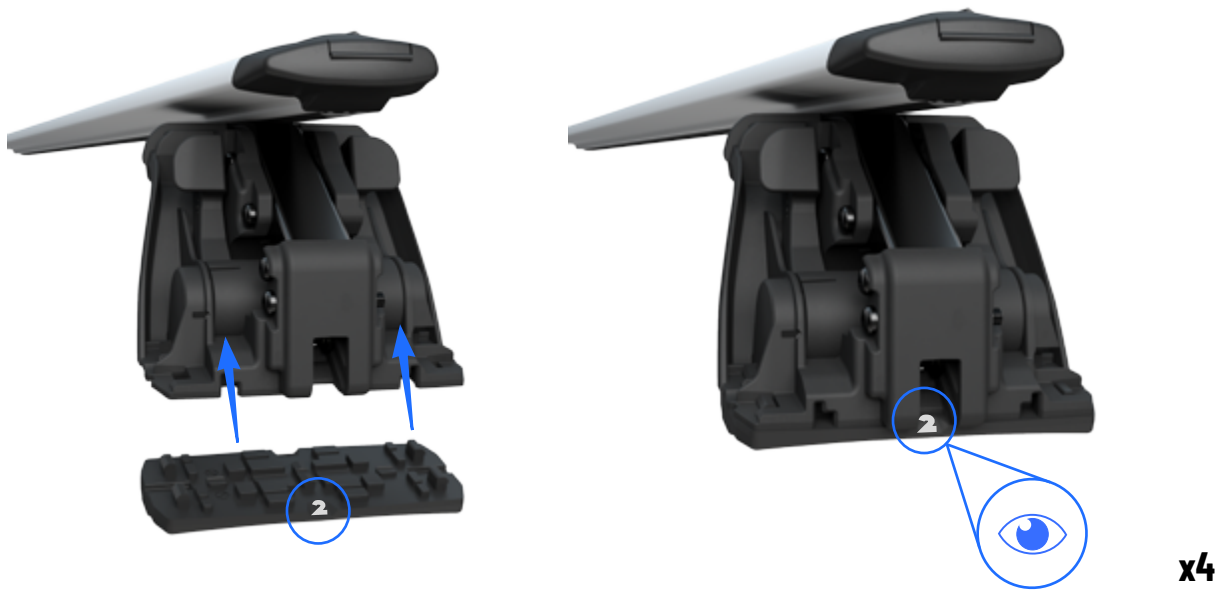
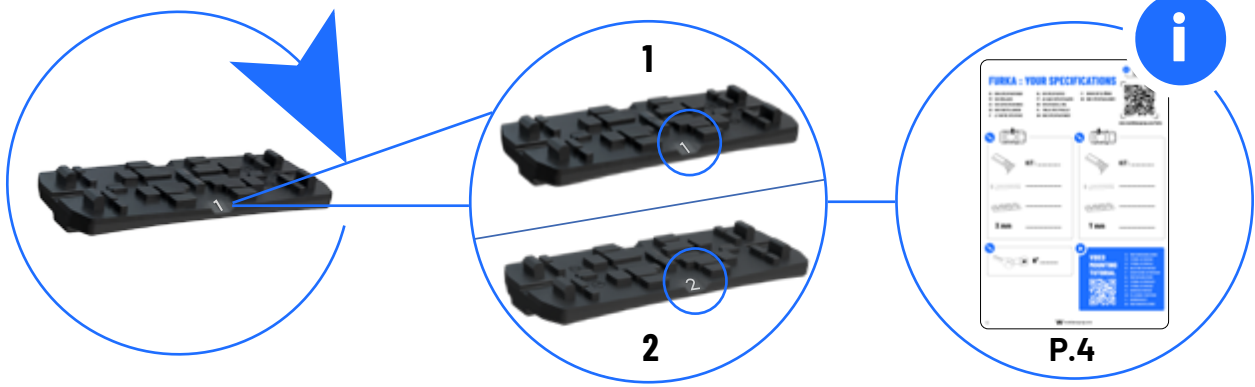

5

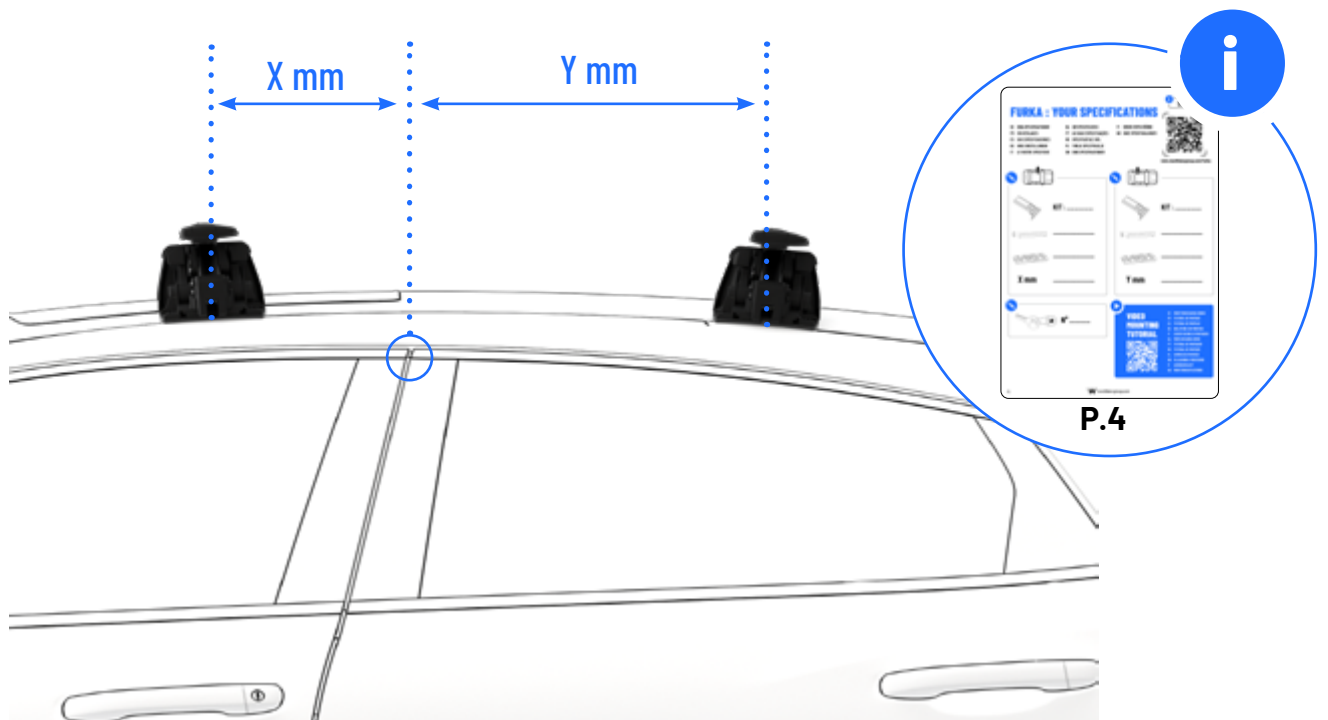

6

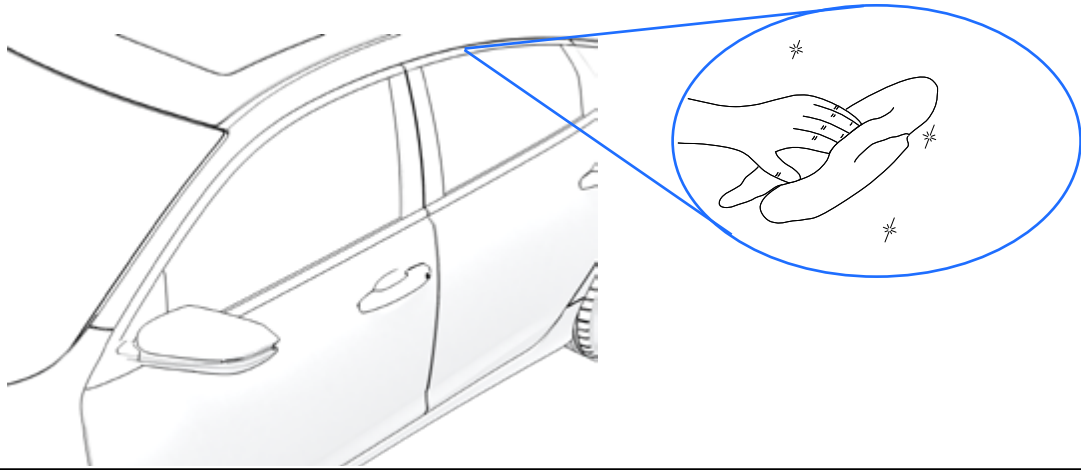

x4

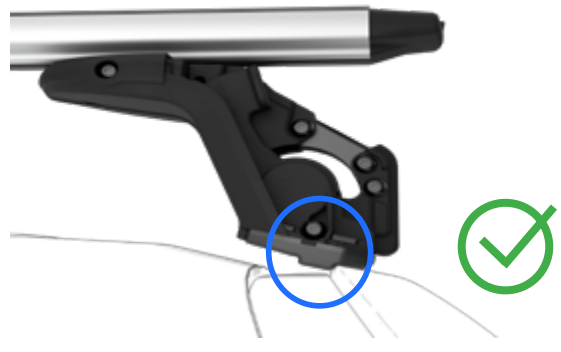
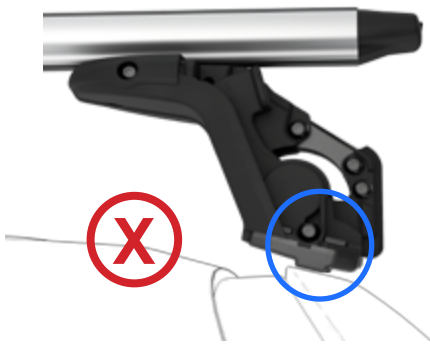

x4

7

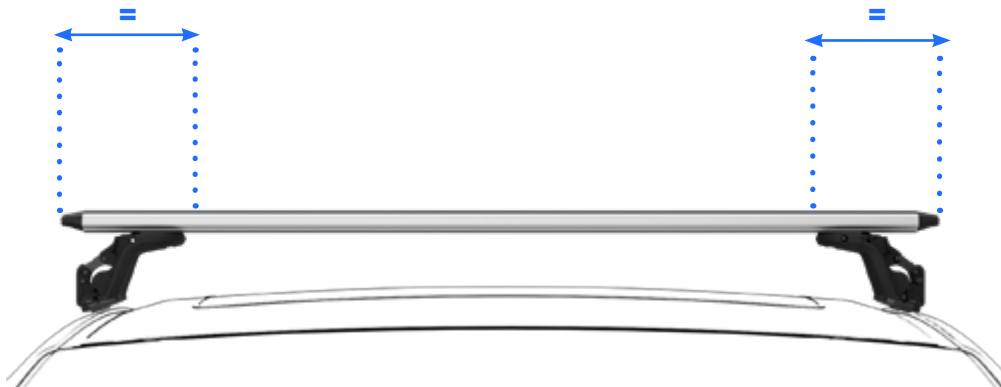

x2

8

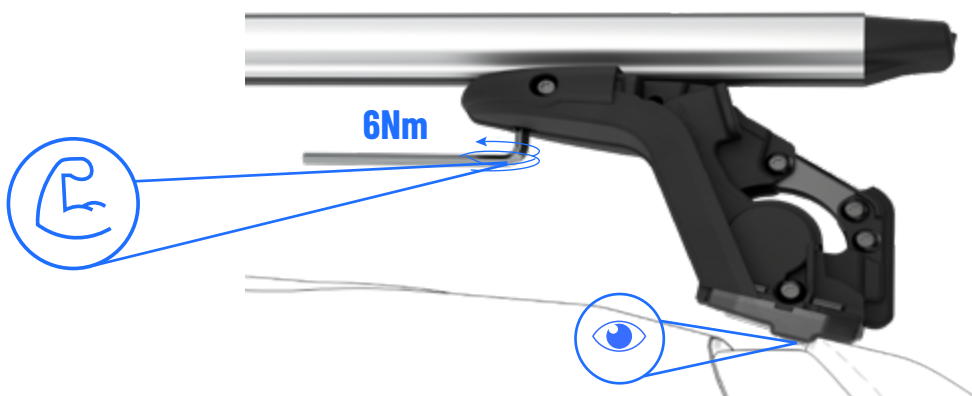

x4

9

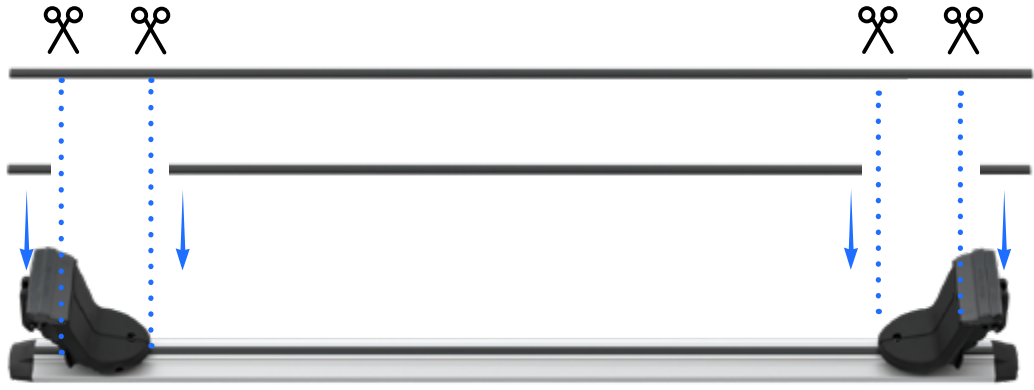

10

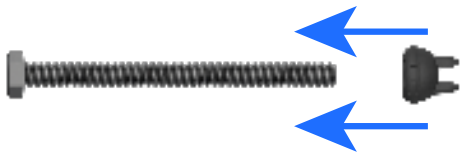
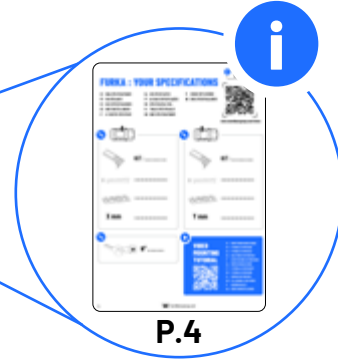
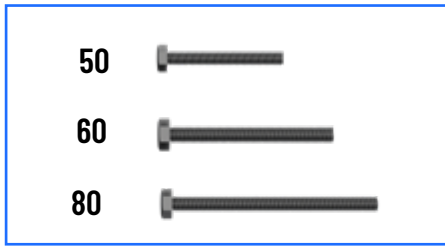

11.a

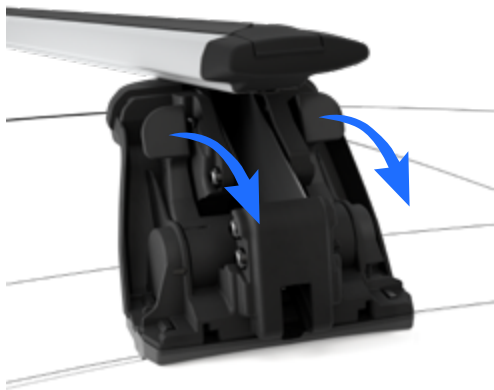

x4

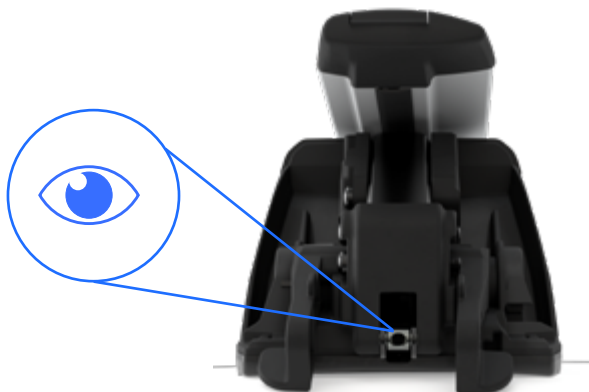

x4



11.b

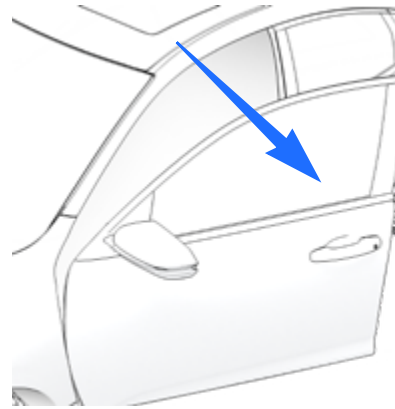

x4

12.a

2+3

FURKA  
ROOF BAR  
CLAMP KIT

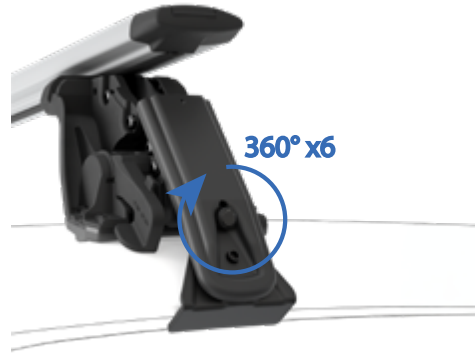

x4

12.b

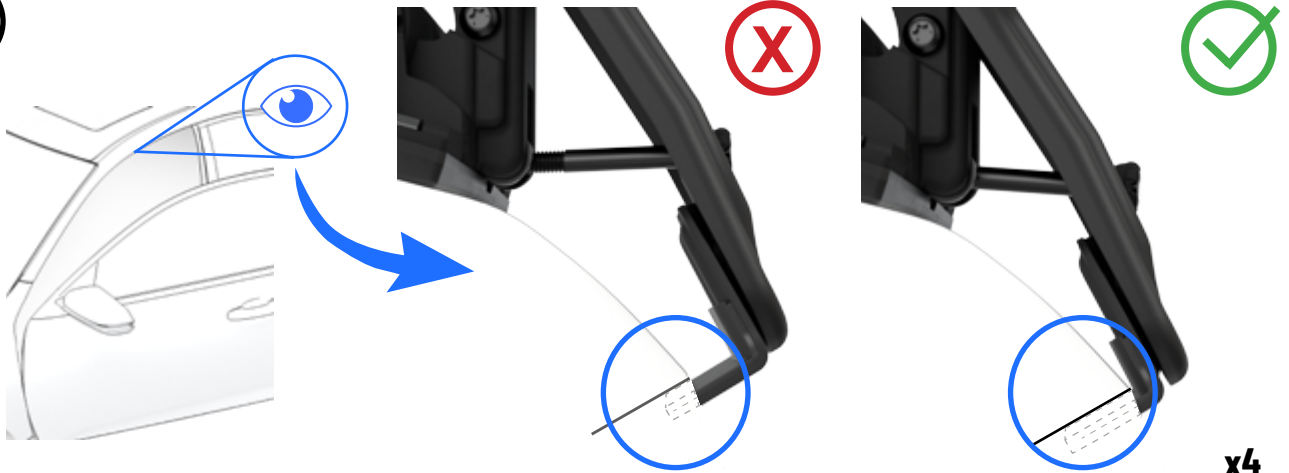

x4

12.c



x4

12.d

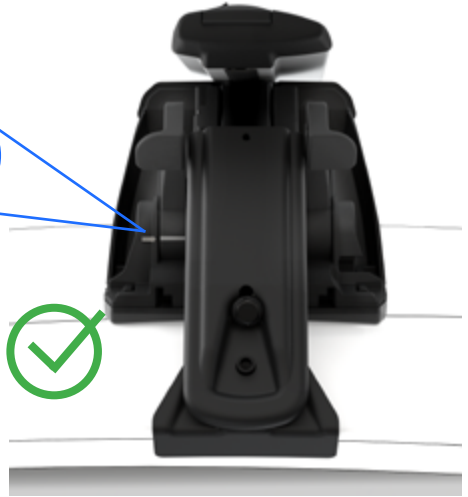
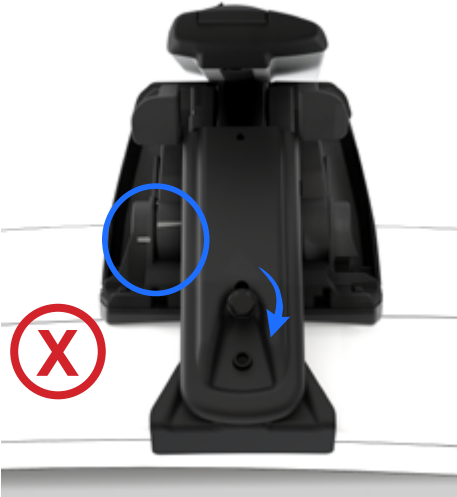
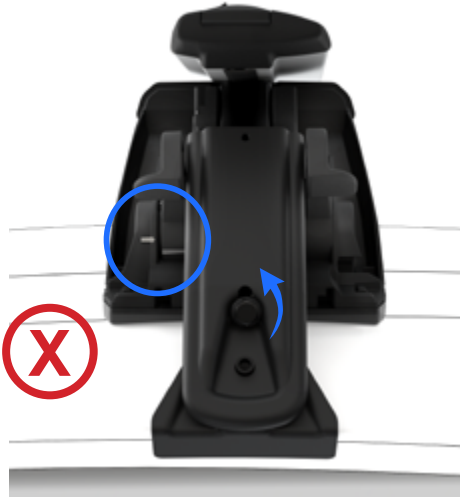
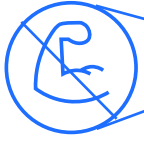

x4

12.e



x4

13

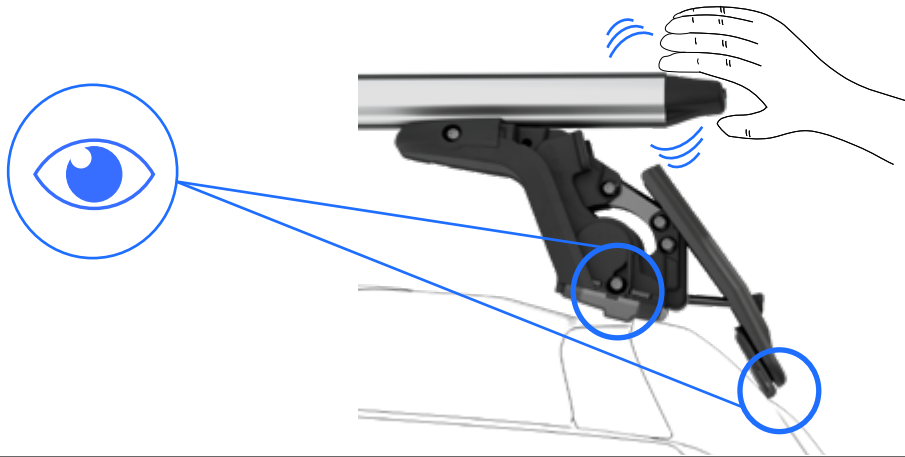

x4

14

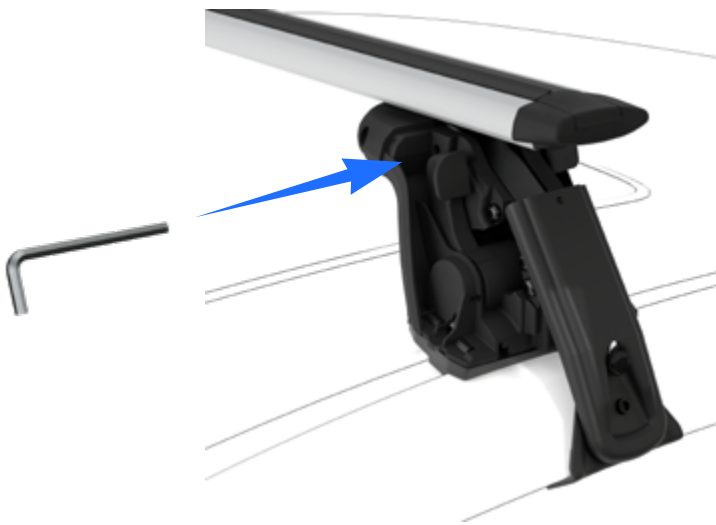

15



x4

## EN - REMOVING AND INSTALLING THE ROOF RACK AGAIN

You only need to use the lever system to remove and install the roof rack again. **Follow steps N° 2 - 5 - 6 - 12b/c/d/e -15.** Please pay attention to distances and keep surfaces clean.

## SE - TA BORT OCH MONTERA TAKRÄCKET IGEN

För att ta bort eller för att montera takräcket igen behöver du bara använda det enkla spaksystemet. **Följ steg nr 2 - 5 - 6 - 12b/c/d/e -15.** Var uppmärksam på avstånden och håll ytorna rena.

## FR - DÉMONTAGE ET RÉINSTALLATION DES BARRES DE TOIT

Il suffit d'utiliser le système de levier pour retirer et réinstaller Furka sur le toit de votre voiture. **Suivez les étapes N° 2 - 5 - 6 - 12b/c/d/e -15.** Veillez à respecter les distances et à garder les surfaces propres.

## ES - RETIRAR E INSTALAR DE NUEVO EL PORTAEQUIPAJES

Para desmontar e instalar de nuevo el portaequipajes, sólo tiene que utilizar el sistema de palanca. **Signa los pasos N° 2 - 5 - 6 - 12b/c/d/e -15.** Preste atención a las distancias y mantenga limpias las superficies.

## DE - ABNEHMEN UND WIEDERANBRINGEN DES DACHTRÄGERS

Zum Aus- und Einbau des Dachträgers brauchen Sie nur das Hebelsystem zu benutzen. **Folgen Sie den Schritten Nr. 2 - 5 - 6 - 12b/c/d/e -15.** Bitte achten Sie auf die Abstände und halten Sie die Oberflächen sauber.

## IT - RIMOZIONE E INSTALLAZIONE DEL PORTAPACCHI:

Per rimuovere e installare nuovamente il portapacchi è sufficiente utilizzare il sistema a leva. **Seguire i passaggi N° 2 - 5 - 6 - 12b/c/d/e -15.** Prestare attenzione alle distanze e mantenere pulite le superfici.

## NL - DE DAKDRAGER OPNIEUW VERWIJDEREN EN INSTALLEREN

U hoeft alleen het hendelsysteem te gebruiken om de dakdrager te verwijderen en opnieuw te installeren. **Volg stappen nr. 2 - 5 - 6 - 12b/c/d/e -15.** Let op de afstanden en houd de oppervlakk-en schoon.

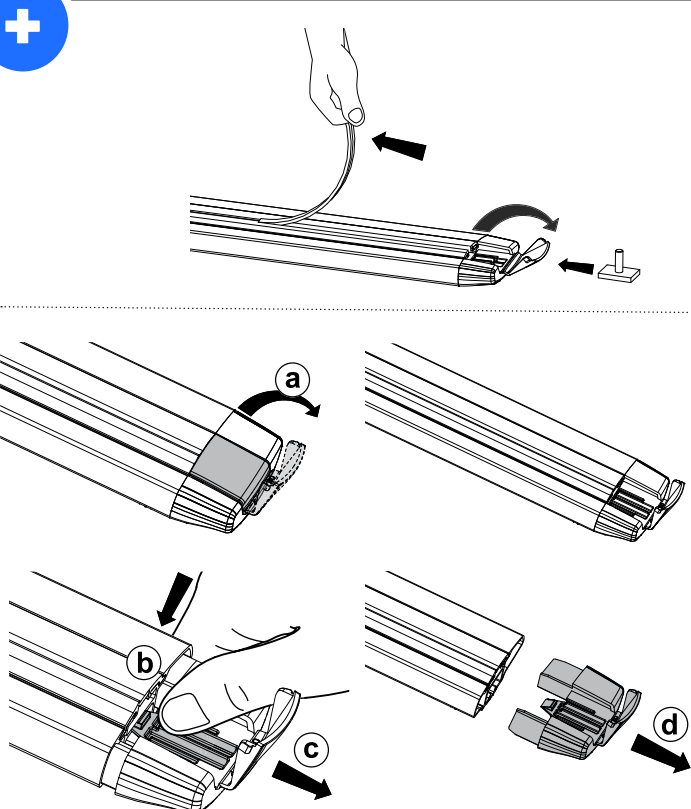

## PT - REMOVER E VOLTAR A INSTALAR AS BARRAS DE TEJADILHO

Para voltar a remover e instalar as barras de tejadilho, basta utilizar o sistema de alavancas. **Siga os passos n.º 2 - 5 - 6 - 12b/c/d/e -15.** Tenha em atenção as distâncias e mantenha as superfícies limpas.

## RO - DEMONTAREA ŞI REINSTALAREA SUPTULUI PE PLAFON

Pentru a demonta şi reinstala suportul pe plafon, este suficient să utilizaţi doar sistemul de pârghii. **Urmaţi paşii nr. 2 - 5 - 6 - 12b/c/d/e -15.** Vă rugăm să acordaţi atenţie distanţelor şi să menţineţi suprafeţele curate.

## PL - PONOWNY DEMONTAŻ I MONTAŻ BAGAŻNIKA DACHOWEGO

Aby ponownie zdemontować i zamontować bagażnik dachowy, wystarczy użyć systemu dźwigni. **Wykonać czynności nr 2 - 5 - 6 - 12b/c/d/e -15.** Należy zwracać uwagę na odległości i utrzymywać powierzchnie w czystości.

## DK - AFMONTERING OG MONTERING AF TAGBAGAGEBÆREREN IGEN

Du skal kun bruge håndtagssystemet til at af- og påmontere tagbagagebæreren igen. **Følg trin nr. 2 - 5 - 6 - 12b/c/d/e -15.** Vær opmærksom på afstande, og hold overfladerne rene.

## FI - KATTOTELINEEN IRROTTAMINEN JA ASENTAMINEN UDELLEEN

Kattotelineen irrottamiseen ja asentamiseen uudelleen tarvitsee käyttää vain vipujärjestelmää. **Noudata vaiheita nro 2 - 5 - 6 - 12b/c/d/e -15.** Huomioi etäisyydet ja pidä pinnat puhtaina.

## NO - TA AV OG SETT PÅ TAKSTATIVET IGJEN

Du trenger bare å bruke spaksystemet for å ta av og montere takstativet igjen. **Følg trinn nr. 2 - 5 - 6 - 12b/c/d/e -15.** Vær oppmerksom på avstander og hold overflatene rene.

